

INSTRUCTION MANUAL

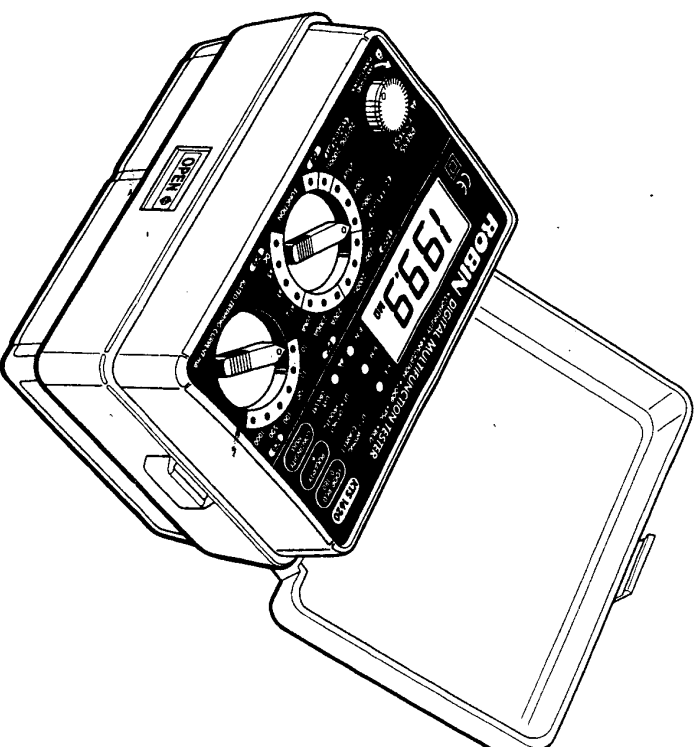

MULTI-FUNCTION TESTER

MODEL KTS 1620

DISTRIBUTOR

92-1365B

99-07

ROBIN ELECTRONICS LIMITED

Precision Centre

Dwight Road, Watford, Herts

WD1 8HG

Telephone Sales : 01923 218744

Administration 01923 232000

Fax 01923 218898

ROBIN

1. SAFE TESTING

Electricity is dangerous and can cause injury and death. Always treat it with the greatest of respect and care. If you are not quite sure how to proceed, stop and take advice from a qualified person.

1. This instrument must only be used by a competent and trained person and operated in strict accordance with the instructions. Robin Electronics will not accept liability for any damage or injury caused by misuse or non-compliance with the instructions or with the safety procedures.
2. It is essential to read and to understand the safety rules contained in the instructions. They must always be observed when using the instrument.
3. This instrument is intended only for single phase operation at 230V AC \pm 10% phase to earth or phase to neutral operation, and then only for loop, prospective short circuit current (PSC) and RCD testing. For use in the continuity testing and insulation testing modes this instrument must be used **ONLY** on circuits which are de-energised.
4. When conducting tests do not touch any exposed metalwork associated with the installation. Such metalwork may become live for the duration of the test.
5. **Never open the instrument case** (except for fuse and battery replacement and in this case disconnect all leads first) because dangerous voltages are present. Only fully trained and competent electrical engineers should open the case. If a fault develops, return the instrument to Robin Electronics for inspection and repair.
6. If the overheat symbol appears in the display () disconnect the instrument from the mains supply and allow to cool down.
7. For loop impedance tests to prevent unwanted tripping during loop testing all residual current devices (RCD's) must be taken out of the circuit and temporarily replaced with a suitably rated MCB unit. The RCD must be replaced after the loop test is completed.
8. If abnormal conditions of any sort are noted (such as a faulty display, unexpected readings, broken case, cracked test leads, etc) do not use the tester and return it to Robin Electronics for repair.
9. For safety reasons only use accessories (test leads, probes, fuses, cases, etc) designed to be used with this instrument and recommended by Robin Electronics. The use of other accessories is prohibited as they are unlikely to have the correct safety features.
10. When testing, always be sure to keep your fingers behind the safety

CAUTION-before taking any measurements always check the leads have been zeroed.

5. Connect the test leads to the circuit whose resistance is required (see Fig 3 for a typical connection arrangement). Having first made sure that the circuit is not live. Note that the live circuit warning lamp will illuminate if the circuit is live - but check first anyway!
6. Press the test button and read the circuit resistance from the display. The reading will have the test lead resistance already subtracted.
7. Note that if the circuit resistance is greater than 20 Ω the instrument will autorange to the 200 Ω , if it is greater than 200 Ω it will autorange to the 2000 Ω range.

Note: If the reading is greater than 2000 Ω the overrange symbol "OL" will remain displayed.

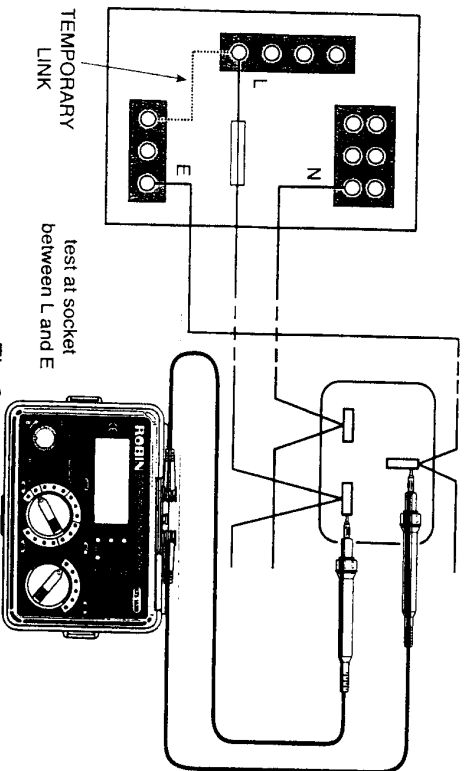

Fig 3

The KTS 1620 is provided with a facility to change the polarity of the test current used by the instrument during continuity tests. This can overcome affects caused by the polarisation of the installation during testing which may give inaccurate readings. To use this function proceed as follows:-

1. Perform a continuity test as outlined in the procedures above.
2. Operate the polarity switch if required.
3. Repeat the continuity tests and the polarity of the test current will be reversed.
4. A comparison can then be made between the two test results which should give the same reading.

200 Ω range and repeat the test to obtain a satisfactory reading. If on the 200 Ω range the over-range symbol is again displayed, switch the instrument up a range to the 2000 Ω range and repeat the test.

Note : Do not connect phase to phase as this instrument is rated at 230V.

9. External Earth Probe: the phase-earth loop impedance is rated at 230V. metalwork (e.g. pipes/conduit etc) can be tested using the external earth probe. Connect the unit to the socket as normal. Plug the external earth probe into the instrument external earth probe socket, ensuring the probe is held with fingers behind the finger guard. This will break the earth continuity at the socket and the red LED will switch on. The point at which the probe is now connected becomes the new earth point instead of at the socket. When the probe is placed in contact with the earthed surface to be measured the LED mains status should revert to the correct sequence as previously described. When this happens, press the test button to measure the loop impedance.

6.5 Loop impedance at 3 phase equipment

Use the same procedure as in 6.4 above ensuring that only one phase is connected at a time i.e. : First Test: red prod to phase 1, black prod to neutral, green crocodile clip to earth.

Second Test: red prod to phase 2, black prod to neutral, green crocodile clip to earth etc.

WARNING : NEVER CONNECT THE INSTRUMENT TO TWO PHASES AT THE SAME TIME.

Testing as described in 6.4 and 6.5 above will measure the Phase-Earth loop impedance. If you wish to measure the Phase-Neutral loop impedance then the same procedure should be followed except the earth clip should be connected to the neutral of the system i.e.: the same point as the black neutral probe.

If the system has no neutral then you must connect the black neutral probe to the earth i.e.: the same point as the green earth clip. This will only work if there is no RCD in this type of system.

8. RCD TESTS

DISCONNECT THE INSTRUMENT FROM THE CIRCUIT UNDER TEST BEFORE OPERATING THE FUNCTION SWITCH TO SELECT THE RCD TEST RANGE SELECT "RCD"

8.1 Purpose of the RCD test

The RCD must be tested to ensure that operation takes place quickly enough to ensure that there is unlikely to be serious danger to a person experiencing an electric shock from the system. This test must NOT be confused with that taking place when the "test" button on the RCD is pressed; operation of the test button simply trips the breaker to ensure that it is working, but does not measure the time taken to break the circuit.

⚠ CAUTION : Setting up to 300mA are effective in the RCD X5 function. In 500/1000mA range current value is limited to approximately 1.7A. Also, setting up to 500mA is effective in the RCD DC function. In 1000mA range current is limited to approximately 600mA.

8.2 What does the RCD test really do?

The RCD is designed to trip out when the difference between the phase current and the neutral current (this is called the residual current) reaches the tripping value (or rating) of the device. The tester provides a carefully preset value of residual current depending on its setting and then measures the time lapse between the application of the current and the operation of the RCD.

8.3 RCD testing

1. Set the RCD rated tripping switch to the trip rating of the RCD under test.
2. Set the function switch to X1/2 for the "no trip" test, which ensures that the RCD is operating within its specification and is not too sensitive.
3. Press the phase selector switch to indicate O° in the display.
4. Connect the instrument to the RCD to be tested either via a suitable socket outlet (see fig 9) or using the SL 16E test lead set (see fig 10).
5. Make sure that the P-E and P-N wiring check lamps are lit and the wiring incorrect  LED is not lit. If they are not, disconnect the tester and check the wiring for a possible fault.
6. If the lamps are correctly lit, press the test button to apply half the rated

Function	Rated Voltage (AC)	Trip Current	Trip Current Duration	Accuracy
RCD X 1/2	230V ± 10% 50Hz	10/30/100/300/500/1000 mA	2000ms	Trip Current: +10% -0% of range at 230V
RCD X 1	230V ± 10% 50Hz	10/30/100/300/500/1000 mA	2000ms	Trip Current: ± 10% of range at 230V
		10 mA		Trip Time ±(1% rdg +3dgt)
RCD X 5	230V ± 10% 50Hz	30/100/300mA (Note: on X 5 range maximum current that can be generated is 1.7A)	50ms	Trip Current: +10% -0% of range at 230V

Function	Rated Voltage	Measuring Range	Accuracy
Voltage Measurement-	100-250V	100-250V	3% rdg

To prevent wrong connection of test leads and to maintain safety, the dedicated terminals used for continuity and insulation tests are automatically covered when using the terminals for loop impedance, PSC and RCD tests

Instrument dimensions:-

130 X 183 X 100mm

Instrument weight:-

1130g including batteries.

Reference conditions

Specifications are based on the following conditions except where otherwise stated:-

1. Ambient temperature: $23 \pm 2^\circ\text{C}$
2. Relative humidity 45% to 75%
3. Position: horizontal
4. AC power source 230V, 50Hz
5. DC power source: 12.0 V, ripple content 1% or less
6. Altitude up to 2000m

Battery type

Eight LR6 ALKALINE batteries.

Low battery warning

" " symbol appears in the display and the buzzer beeps if the battery voltage drops below 7.8V.

Operating temperature and humidity.

0 to +40°C, relative humidity 80% or less, no condensation.

- Electronic fluorescent starter switches
- Passive infra-red detectors (PIR)s
- Dimmer switches
- Touch switches
- Delay timers
- Power controllers
- Emergency lighting units
- Electronic RCDS
- Computers and printers
- Electronic point-of-sale terminals (cash registers)
- Any other device which includes electronic components.

5.3 Preparation for measurement

Before testing, always check the following:-

1. The "low battery" Indication "**Lo**" is not displayed
2. There is no visually obvious damage to the tester or to the test leads
3. Test the continuity of the test leads by switching to continuity test and shorting out the lead ends. A high reading will indicate that there is a faulty lead or that the fuse is blown.
4. **MAKE SURE THAT THE CIRCUIT TO BE TESTED IS NOT LIVE.** A warning lamp is lit if the instrument is connected to a live circuit but test the circuit as well!

5.4 Insulation resistance measurement

The KTS 1620 has a selectable, triple test voltage of 250V, 500V and 1000V DC.

1. Select the insulation resistance setting by rotating the function dial to the required test voltage - 250V, 500V or 1000V as indicated under the "insulation" test section of the functional switch, after making sure that the instrument is not connected to a live circuit.
2. Attach the test leads to the instrument and to the circuit or the appliance under test (see Figs 7 & 8)

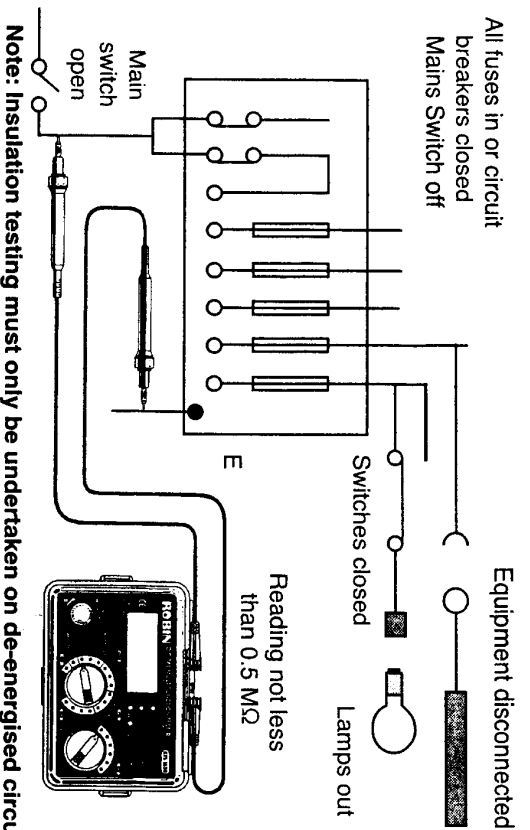

Fig 7

3. If the mains warning lamp lights and/or the buzzer sounds DO NOT PRESS THE TEST BUTTON but disconnect the instrument from the circuit. Make the circuit dead before proceeding.

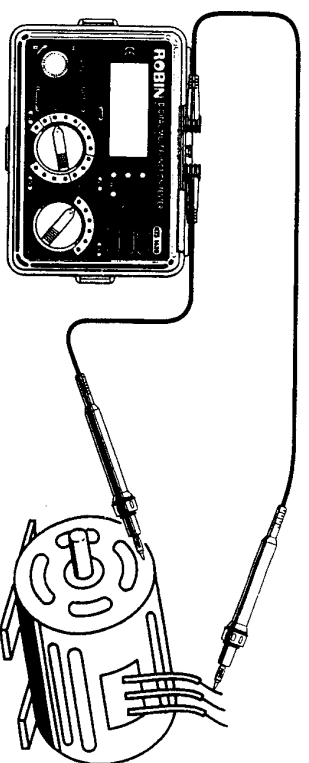

Fig 8

4. Press the test button when the display will show the insulation resistance of the circuit or the appliance to which the instrument is connected.
5. Note that if the circuit resistance is greater than 20MΩ the instrument will automatically range to the 200MΩ reading.

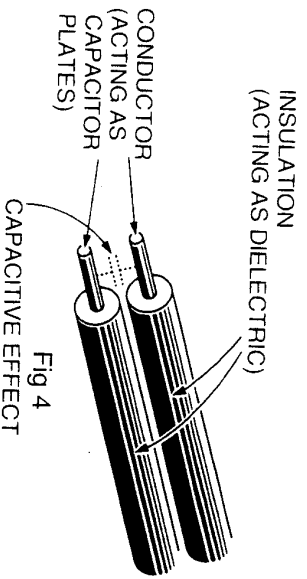

Fig 4

5. 1. 3 Conduction Current

Since the insulation resistance is not infinite, a small leakage current flows through the insulation between conductors. Since Ohm's Law applies, the leakage current can be calculated from

$$\text{Leakage current } (\mu\text{A}) = \frac{\text{applied voltage (V)}}{\text{insulation resistance (M}\Omega\text{)}}$$

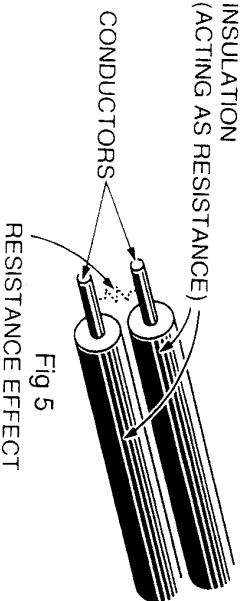

Fig 5

5. 1. 4 Surface Leakage Current

Where insulation is removed, for the connection of conductors and so on, current will flow across the surfaces of the insulation between the bare conductors. The amount of leakage current depends on the condition of the surfaces of the insulation between the conductors. If the surfaces are clean and dry, the value of the leakage current will be very small. Where the surfaces are wet and/or dirty, the surface leakage current may be significant. If it becomes large enough, it may constitute a flashover between the conductors.

Whether this happens depends on the condition of the insulation surfaces and on the applied voltage; this is why insulation tests are carried out at higher voltages than those normally applying to the circuit concerned.

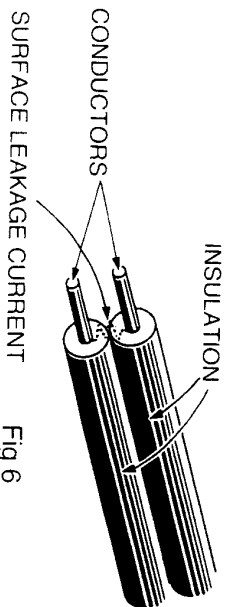

Fig 6

6. LOOP IMPEDANCE TESTS

DISCONNECT THE INSTRUMENT FROM THE CIRCUIT UNDER TEST BEFORE OPERATING THE FUNCTION SWITCH

TO SELECT THE LOOP TESTING RANGE SELECT "LOOP"

6.1 Voltage Measurement

When the tester is set to the loop test function, mains voltage is displayed as soon as the instrument is connected for test. This voltage display is automatically updated five times every second. The voltage function operates whenever the test button is in the up position.

6.2 What is earth fault loop impedance?

The path followed by fault current as a result of a low impedance fault occurring between the phase conductor and earth is called earth fault loop. Fault current is driven round the loop by the supply voltage, the amount of current depending on the voltage of the supply and on the impedance of the loop. The higher the impedance, the lower will be the fault current and the longer it will take for the circuit protection (fuse or circuit breaker) to operate and interrupt the fault.

To make sure that fuses will blow or that circuit breakers will operate quickly enough in the event of a fault, the loop impedance must be low, the actual maximum value depending on the characteristics of the fuse or the circuit breaker concerned. The IEE Regulations (BS 7671) provides tables showing the maximum permissible values of loop impedance in circuits protected by various fuses and circuit breakers. Every circuit must be tested to make sure that the actual loop impedance does not exceed that specified for the protective device concerned.

6.3 Automatic over-temperature cut-out

During the short test period the instrument dissipates power of about 6 kW. If frequent tests are conducted over a prolonged period of time, the internal test resistor will overheat. When this happens, further tests are automatically inhibited and the over-temperature symbol () appears in the display. The instrument must then be left to cool down, when testing may be resumed.

3. SPECIFICATION

Measurement Specification

Function	Open Circuit Voltage (DC)	Short Circuit Current	Range	Accuracy
Continuity	Greater than 6 V	Greater than 200mA as per BS7671	20/200/2000 Ω Auto- Ranging	± (1.5%/rdg + 3dgt)

Function	Open Circuit Voltage (DC)	Rated Current	Range	Accuracy
Insulation Resistance	250V +20%–0%	1mA or greater @ 250K Ω as per BS7671	20/200 M Ω Auto-Ranging	± (1.5%/rdg + 3dgt)
	500V +20%–0%	1mA or greater @ 500K Ω as per BS7671	20/200 M Ω Auto-Ranging	± (1.5%/rdg + 3dgt)
	1000V +20%–0%	1mA or greater @ 1M Ω as per BS7671	20/200 M Ω Auto-Ranging	± (1.5%/rdg + 3dgt)

Function	Rated Voltage (AC)	Nominal Test Current at 0 Ω External Loop	Range	Accuracy
Loop Impedance	230V ± 10% 50Hz	25A	20 Ω	± (3%/rdg + 4dgt)
	230V ± 10% 50Hz	2.3A	200 Ω	± (3%/rdg + 4dgt)
	230V ± 10% 50Hz	225mA	2000 Ω	± (3%/rdg + 4dgt)

Prospective Short Circuit Current (PSC)	230V ± 10% 50Hz	2.3A	200A	PSC accuracy is a derived from measured loop impedance specification and measured voltage specification
		25A	2000A	
		25A	20KA	

- tripping current for 2000 ms, when the RCD should **not** trip. The PN and PE LEDs should remain on indicating the RCD has not tripped.
- Press the phase selector switch to indicate 180° in the display and repeat the test.
- In the event of the RCD tripping, the trip time will be displayed, but the RCD maybe faulty.
- Set the function switch to X1 for the “trip” test, which measures the time taken for the RCD to trip with the set residual current.
- Press the phase selector switch to indicate 0° on the display.
- Make sure that the P-E and P-N wiring check lamps are lit. If they are not, disconnect the tester and check the wiring for a possible fault.
- If the lamps are lit, press the test button to apply full rated tripping current and the RCD should trip, the tripping time being shown on the display. If the RCD has tripped the PN and PE LEDs should be off. Check this is so.
- Press the phase selector switch to indicate 180° in the display and repeat the test.
- MAKE SURE TO KEEP CLEAR OF EARTHED METAL DURING THE OPERATION OF THESE TESTS.**

8.4 Testing RCDs used to provide supplementary protection. (X5 TRIP TEST)

RCDs rated at 30 mA or less are sometimes used to provide extra protection against electric shock. Such RCDs require a special test procedure as follows:-

- Set the function switch to X5 for the “fast” trip test.
- Press the phase selector switch to indicate 0° in the display.
- Connect the test instrument to the RCD to be tested.
- Make sure that the P-E and P-N wiring check lamps are lit. If they are not, disconnect the tester and check the wiring for a possible fault.
- If the lamps are lit, press the test button to apply a test current of 150mA where the RCD should trip within 40ms, the tripping time being shown on the display.
- Press the phase selector switch to indicate 180° in the display and repeat the test.
- MAKE SURE TO KEEP CLEAR OF EARTHED METAL DURING THE OPERATION OF THIS TEST.**

8.5 Testing time delayed RCDs

RCDs with a built-in time delay are used to ensure discrimination, that is, that the correct RCD operates first. Testing is carried out in accordance with item 8.3 above, except that the displayed tripping times are likely to be longer than those for a normal RCD. Since the maximum test time is longer, there may be danger

barriers on the test leads.

11. During testing it is possible that there may be a momentary degradation of the reading due to the presence of excessive transients or discharges on the electrical system under test. Should this be observed, the test must be repeated to obtain a correct reading. If in doubt, contact Robin Electronics.
12. The sliding shutter on the back of the instrument is a safety device. The instrument should not be used if it is damaged or impaired in any way, but returned to Robin Electronics for attention.
13. Robin recommends the use of fused test leads particularly when measuring voltages in high energy circuits. Where assessments show that the risk is significant, then the use of fuse test leads constructed in accordance with the HSE Guidance Note GS38 should be used. The test accessories used with this instrument for loop impedance and RCD tests are all fused.
14. Do not operate the function selector whilst the instrument is connected to a circuit. If, for example, the instrument has just completed a continuity test and an insulation test is to follow, disconnect the test leads from the circuit before moving the selector switch.
15. Do not rotate function dial when test button is depressed. If the function switch is inadvertently moved to a new function when the test button is depressed or in lock-down position the test in progress will be halted. To reset, release test button and press again to restart testing on new function.

BATTERY LIFE

Note:

Always switch the selector dial to the OFF position after each testing period. This will conserve battery power.

INSULATION / CONTINUITY TESTS

Note:

Only use the SL20 test leads supplied with this tester and always ensure that they are plugged fully into the unit's 4mm terminals to guarantee a sound and proper connection.

13. CASE AND STRAP ASSEMBLY

Correct assembly is shown in Fig 12. By hanging the instrument round the neck, both hands will be left free for testing.

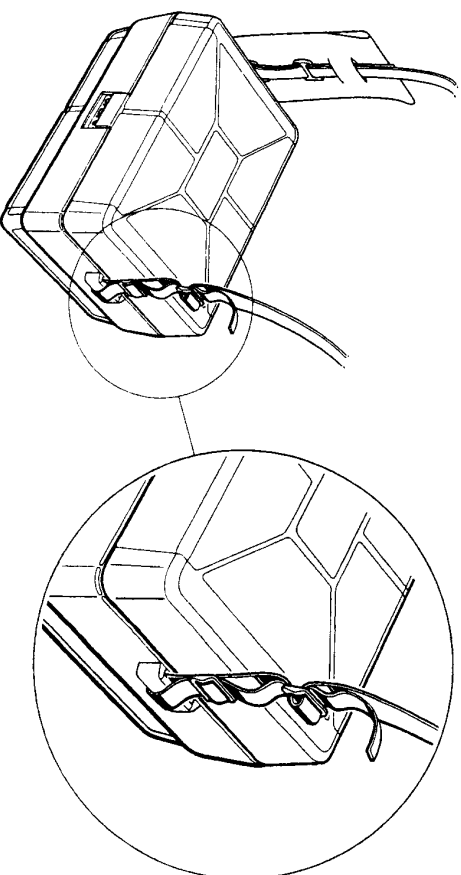

Fig12

12. SERVICING

If this tester should fail to operate correctly, return it to Robin Electronics stating the exact nature of the fault. Before returning the instrument ensure that:-

1. The leads have been checked for continuity and signs of damage.
2. The continuity mode fuse (situated in the battery compartment) has been checked.
3. The batteries are in good condition.

Please remember to give all the information possible concerning the nature of the fault, as this will mean that the instrument will be serviced and returned to you more quickly.

Return the instrument to:-

Service Department
Robin Electronics Limited
Precision Centre
Dwight Road
Watford
Herts
WD1 8HG
England
Telephone 01923 218833
Fax 01923 222612

Regular re-calibration is recommended for this instrument. Robin recommends that with normal use, the instrument be calibrated at least once in every 12 month interval. When the instrument is due for re-calibration return it to the address above marked for the attention of the Calibration Department and be sure to include all accessory leads, as these are part of the calibration procedure.

2. FEATURES

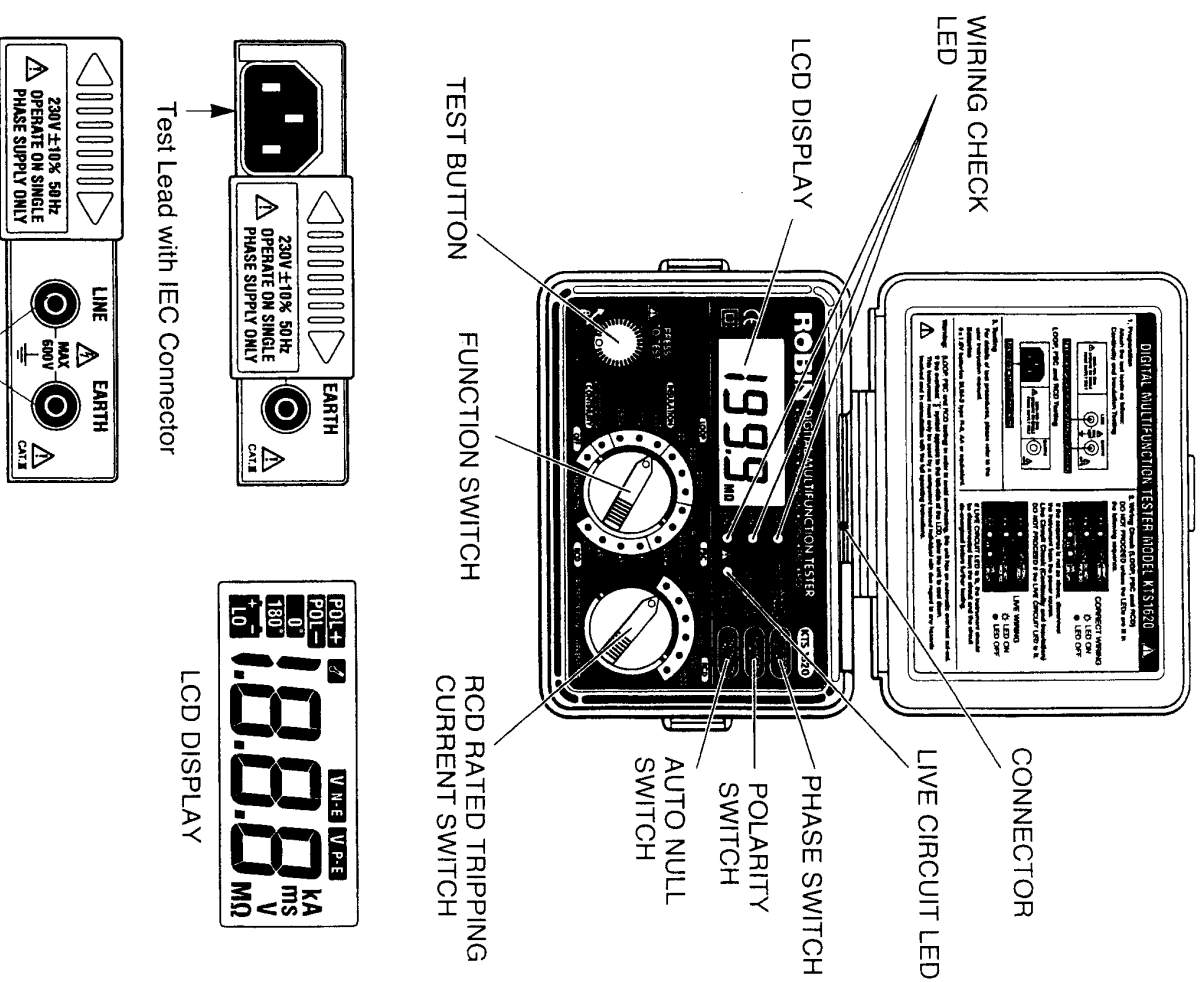
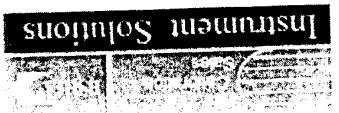

Fig. 1

Test Lead for Continuity and Insulation Testing



Old Bracknell Lane West, Bracknell, Berkshire, RG12 7AH, UK
Tel: +44 (0) 1344 459314 Fax: +44 (0) 1344 465556
Sales : sales@bis.frm Hire : hire@bis.frm Calibration : calibration@bis.frm

Hire Calibration Thermal Imaging Site Services
Sales News | Products A to Z | My Quote | Contact Us | About Us

Electrical / Multifunction - installation testers

New search

Robin : KTS 1620

The KTS1620 is Robin's mid level 5 in 1 Digital multifunction tester for electrical installations to the requirements of BS 7671.

The KTS1620 provides 5 primary test functions of

- Continuity Tester
- Insulation Tester
- Loop Impedance tester
- RCD Tester.
- PSC Tester.

All in a compact, light, and portable design. Included with the KTS 1620 as standard are SL20 Snap-Lok Test Lead; distribution board test leads, BS 1363 moulded plug lead, carrying cas

KEY FEATURES

- Continuity & Insulation Test Function
- Visual Live Circuit warning lamp.
- Continuity Null function. Enables the removal of test lead resistance testing.
- Integral Overload protection. Protection on internal continuity & insi
- 250, 500V & 1000V DC Insulation test function voltages.
- Polarity switch. Allows switching of polarity during Insulation & cont

KEY FEATURES (Cont'd)

- LOOP Impedance Test Functions
- Visual correct wiring warning lamp.
- Integral Overheat protection. Protection on internal circuitry against
- Supply voltage indication.
- Low current Loop Impedance Test.
- Auto Data hold.
- Auto Power Off.
- RCD Test Functions
- Auto Data hold.
- Phase angle selection. Selection of test current from +ve & -ve half
- x1/2 & x5 RCD current multipliers.
- DC Test. Allows the testing of RCD's which are sensitive to DC fault
- 19 Possible test RCD trip current settings.

FUNCTION RANGE ACCURACY

- Continuity Resistance 0 to 19.99 ohm
- 10.0 to 199.9 ohm
- 100 to 2000 ohm $\pm(1.5\% \text{ ind} + 3 \text{ digits})$
- $\pm(1.5\% \text{ ind} + 3 \text{ digits})$
- Insulation Resistance
- (250, 500, 1000V DC) 0 to 100 Mohm
- 100 to 2000 Mohm $\pm(1.5\% \text{ ind} + 3 \text{ digits})$
- $\pm(1.5\% \text{ ind} + 3 \text{ digits})$
- Loop Impedance 20.00 ohm (Nominal 25 A current)
- 200.0 ohm (Nominal 2.3 A current)
- 2000 ohm (Nominal 225 mA Current) $\pm(2\% \text{ ind} + 2 \text{ digits})$
- RCD Testing x1/2 :- 5, 15, 50, 150, 250, 500 mA
- x1 :- 10, 30, 100, 300, 500, 1000 mA
- x5 :- 50, 150, 500 mA $\pm(1\% \text{ ind} + 3 \text{ digits})$ trip time

KTS 1620

Models, availability and pricing

KTS 1620

Price	Availability	
Call	<input type="checkbox"/>	Hire
Call	<input type="checkbox"/>	Sale
Call	<input type="checkbox"/>	Calibration



Get quote to... Buy quantity... add to quote

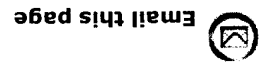

Do you know a colleague who will be interested in these products? Send them a link to this page.

Top of page

Home : Sales : Hire : Services : Calibration : Contact Us
Privacy policy : Copyright © 2002 BSRIA Instrument Solutions : Terms and Conditions : Logout :

INDUSTRIAL CALIBRATION LIMITED

REPAIR AND CALIBRATION OF TEST EQUIPMENT

Sales : sales@bis.firm Hire : hire@bis.firm Calibration : calibration@bis.firm

Hire Calibration Thermal Imaging Site Services

Home | News | Products A to Z | My Quote | Contact Us | About Us

Electrical / Multifunction - installation testers

New search

Robin : KTS 1620

The KTS1620 is Robin's mid level 5 in 1 Digital multifunction tester for electrical installations to the requirements of BS 7671.

The KTS1620 provides 5 primary test functions of

- Continuity Tester
- Insulation Tester
- Loop Impedance tester
- RCD Tester.
- PSC Tester.

All in a compact, light, and portable design.

Included with the KTS 1620 as standard are SL20 Snap-Lok Test Lead; distribution board test leads, BS 1363 moulded plug lead, carrying case; Instruction Manual, & Certificate of Conformity.

KEY FEATURES

- Continuity & Insulation Test Function
- Visual Live Circuit warning lamp.
- Continuity Null function. Enables the removal of test lead resistance testing.
- Auto discharge. Allows fast & safe electrical discharge of capacitance testing.
- Integral Overload protection. Protection on internal continuity & insulation test function voltages.
- 250, 500V & 1000V DC Insulation test function voltages.
- Polarity switch. Allows switching of polarity during Insulation & continuity testing.

KEY FEATURES (Cont'd)

- LOOP Impedance Test Functions
- Visual correct wiring warning lamp.
- Integral Overheat protection. Protection on internal circuitry against
- Supply voltage indication.
- Low current Loop Impedance Test.
- Auto Data hold.
- Auto Power Off.
- RCD Test Functions
- Auto Data hold.
- Phase angle selection. Selection of test current from +ve & -ve half
- x1/2, x1 & x5 RCD current multipliers.
- DC Test. Allows the testing of RCD's which are sensitive to DC fault
- 19 Possible test RCD trip current settings.

FUNCTION RANGE ACCURACY

- Continuity Resistance 0 to 19.99 ohm
- 10.0 to 199.9 ohm
- 100 to 2000 ohm $\pm(1.5\% \text{ ind} + 3 \text{ digits})$
- $\pm(1.5\% \text{ ind} + 3 \text{ digits})$
- Insulation Resistance (250, 500, 1000V DC) 0 to 100 Mohm
- 100 to 2000 Mohm $\pm(1.5\% \text{ ind} + 3 \text{ digits})$
- $\pm(1.5\% \text{ ind} + 3 \text{ digits})$
- Loop Impedance 20.00 ohm (Nominal 25 A current)
- 200.0 ohm (Nominal 2.3 A current)
- 2000 ohm (Nominal 225 mA Current) $\pm(2\% \text{ ind} + 2 \text{ digits})$
- RCD Testing x1/2 :- 5, 15, 50, 150, 250, 500 mA
- x1 :- 10, 30, 100, 300, 500, 1000 mA
- x5 :- 50, 150, 500 mA $\pm(1\% \text{ ind} + 3 \text{ digits})$ trip time

Date Signature

Home : Sales : Hire : Services : Calibration : Contact Us
Privacy policy : Copyright © 2002 BSRIA Instrument Solutions : Terms and Conditions : Logout :

Top of page

Do you know a colleague who will be interested in these products? Send them a link to this page.

Email this page



Quote



Get quote to... Buy quantity... 1 add to quote

Price	Availability	
Call	<input type="checkbox"/>	Calibration
Call	<input type="checkbox"/>	Sale
Call	<input type="checkbox"/>	Hire

KTS 1620

INDUSTRIAL CALIBRATION LIMITED
 REPAIR AND CALIBRATION OF TEST EQUIPMENT
 Models, availability and pricing



4. CONTINUITY (RESISTANCE) TESTS

⚠ WARNING
ENSURE THAT CIRCUITS TO BE TESTED ARE NOT LIVE.

DISCONNECT THE INSTRUMENT FROM THE CIRCUIT UNDER TEST BEFORE OPERATING THE FUNCTION SWITCH.

TO SELECT THE LOW RESISTANCE RANGE SELECT "CONTINUITY"

4. 1 Instrument layout See Fig 1.

4. 2 Test Procedure

The object of continuity testing is to measure only the resistance of the parts of the wiring system under test. This measurement should not include the resistance of any test leads used. The resistance of the test leads needs to be subtracted from any continuity measurement. The KTS 1620 is provided with a continuity null feature which allows automatic compensation for any test lead resistance.

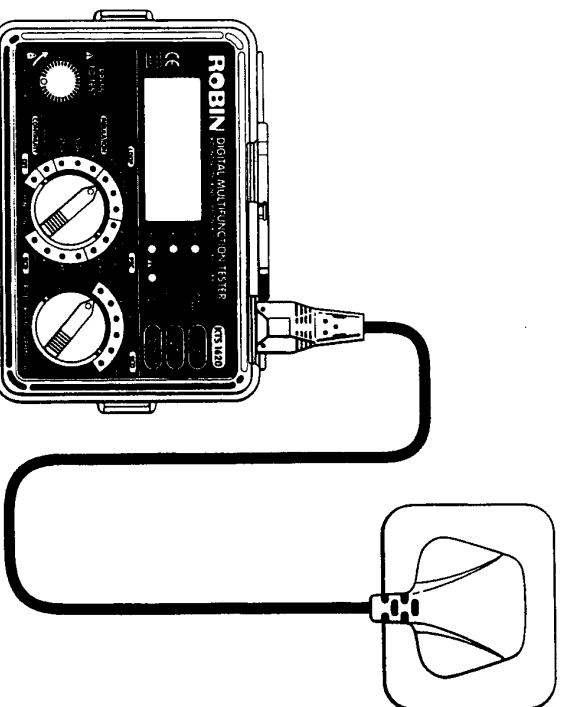

Fig 9

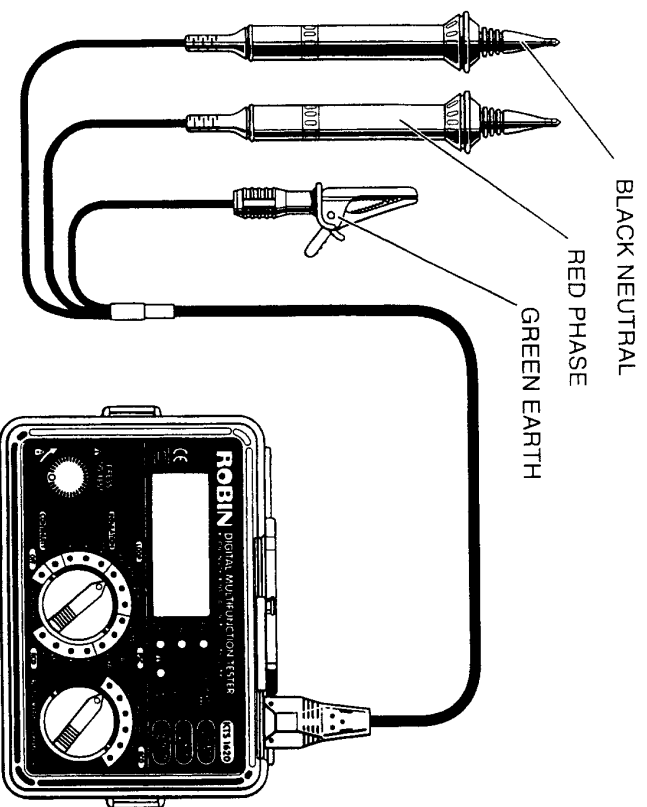

Fig 10

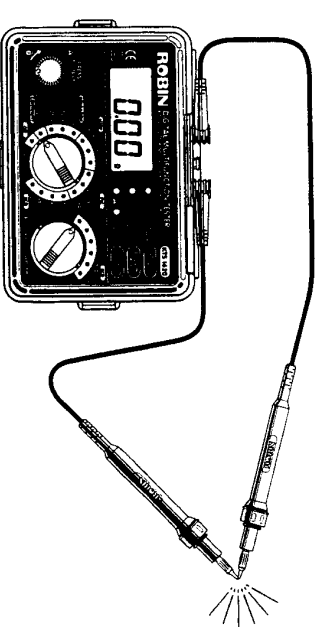

Fig 2

Proceed as follows:-

1. Select the continuity test by rotating the function dial.
2. Connect the ends of the test leads firmly together (see Fig 2) and press and lock down the test button. The value of the lead resistance will be displayed.
3. Operate the Continuity Null button, this will null out the lead resistance and the indicated reading should go to zero.
4. Release the test button. Press the test button and ensure the display reads zero before proceeding. If the function switch is moved to the OFF position, the lead null value will be lost and the above procedure must be repeated.

6.4 The loop impedance test

Since the earth fault loop is made up of conducting path which includes the supply system back to the supply transformer, it follows that loop testing can only be carried out after the mains supply has been connected. In many cases, any RCD in the circuit will be tripped by this test, which draws current from the phase and returns it through the earth system. The RCD will see this as the type of fault it is designed to protect against, and will trip. To prevent this unwanted RCD tripping during loop testing, any RCD must be taken out of circuit and temporarily replaced with a suitably rated MCB unit. The RCD will need to be replaced after the loop test is completed.

WARNING

DO NOT PROCEED WITH TESTING UNLESS THE P-E AND P-N LAMPS ARE LIT TO CONFIRM THAT THE WIRING IS CORRECTLY CONNECTED. Should these two lamps not be lit, investigate the wiring connections of the installation and rectify any faults before proceeding with the test. If the  LED is lit do not proceed.

1. Set the instrument to loop test 20 Ω range.
2. If testing sockets, connect the plug lead to the KTS 1620 and push the moulded plug into the socket to be tested (see Fig 9).
3. Check the wiring lamps are lit (see above).
4. Note the mains voltage displayed by the instrument.
5. Press the “Press to test” button. The value of the measured loop impedance will be displayed with the appropriate units.
6. If testing lighting or other circuits, connect the three-wire lead SL 16E to the KTS 1620, connect the red (phase) lead to the phase connection of the circuit under test, connect the black (neutral) lead to the neutral connection of the circuit under test, and connect the earth lead to the earth associated with the circuit. (see Fig 10).
7. If any RCD associated with the circuit trips out, reset the RCD and try testing again, this time operating the phase selector switch once prior to pressing the test button. This will change the period of the waveform over which the instrument performs the loop test. This may result in the RCD not tripping out. If the RCD still trips, temporarily replace it with a suitably rated MCB for the duration of the test.
8. If the instrument measures greater than 20 Ω the over-range symbol “OL” will be displayed. If this is the case, switch the instrument up a range to the

5. INSULATION TESTS

WARNING

ENSURE THAT CIRCUITS TO BE TESTED ARE NOT LIVE.

DISCONNECT THE INSTRUMENT FROM THE CIRCUIT UNDER TEST BEFORE OPERATING THE FUNCTION SWITCH.

TO SELECT THE INSULATION RESISTANCE RANGE SELECT “INSULATION”

5. 1 The nature of insulation resistance

Live conductors are separated from each other and from earth metal by insulation, which has a resistance which is high enough to ensure that the current between conductors and to earth is kept at an acceptably low level. Ideally insulation resistance is infinite and no current should be able to flow through it. In practice, there will normally be a current between live conductors and to earth, and this is known as leakage current. This current is made up of three components, which are:-

1. capacitive current
2. conduction current, and
3. surface leakage current.

5. 1. 2 Capacitive Current

The insulation between conductors which have a potential difference between them behaves as the dielectric of a capacitor, the conductors acting as the capacitor plates. When a direct voltage is applied to the conductors, a charging current will flow to the system which will die away to zero (usually in less than a second) when the effective capacitor becomes charged. This charge must be removed from the system at the end of the test, a function which is automatically performed by the KTS 1620. If an alternating voltage is applied between the conductors, the system continuously charges and discharges as the applied voltage alternates, so that there is a continuous alternating leakage current flowing to the system.

6. When testing is complete release the test button BEFORE disconnecting the test leads from the circuit or from the appliance. This will ensure that the charge built up by the circuit or the appliance during insulation test is dissipated in the discharge circuit. In the discharging process, an LED illuminates and the live circuit warning buzzer will sound.

CAUTION
NEVER TURN THE FUNCTION DIAL WHILE THE TEST BUTTON IS DEPRESSED AS THIS MAY DAMAGE THE INSTRUMENT. NEVER TOUCH THE CIRCUIT, TEST LEAD TIPS OR THE APPLIANCE UNDER TEST DURING INSULATION TESTING.

Note : If the reading measured greater than 200M Ω the over range reading "OL" will be displayed.

5. 1. 5 Total Leakage Current

The total leakage current is the sum of the capacitive, conduction and surface leakage current described above. Each of the currents, and hence the total leakage current, is affected by factors such as ambient temperature, conductor temperature, humidity and the applied voltage.

If the circuit has alternating voltage applied, the capacitive current (5.1.2) will always be present and can never be eliminated. This is why a direct voltage is used for insulation resistance measurement, the leakage current in this case quickly falling to zero so that it has no effect on the measurement. A high voltage is used because this will often break down poor insulation and cause flashover due to surface leakage (see 5.1.4), thus showing up potential faults which would not be present at lower levels. The insulation tester measures the applied voltage level and the leakage current through the insulation. These values are internally calculated to give the insulation resistance using the expression:-

$$\text{Insulation resistance (M}\Omega\text{)} = \frac{\text{Test voltage (V)}}{\text{Leakage current (\mu A)}}$$

As the capacitance of the system charges up, so the charging current falls to zero and a steady insulation resistance reading indicates that the capacitance of the system is fully charged. The system is charged to the full test voltage, and will be dangerous if left with this charge. The KTS-1620 provides an automatic path for discharging current as soon as the test button is released to ensure that the circuit under test is safely discharged.

If the wiring system is wet and/or dirty, the surface leakage component of the leakage current will be high, resulting in low insulation resistance reading. In the case of a very large electrical installation, all the individual circuit insulation resistances are effectively in parallel and the overall resistance reading will be low. The greater the number of circuits connected in parallel the lower will be the overall insulation resistance.

5. 2 Damage to Voltage-Sensitive Equipment

An increasing number of electronic-based items of equipment are being connected to electrical installations. The solid state circuits in such equipment are likely to be damaged by the application of the levels of voltage used to test insulation resistance. To prevent such damage, it is important that voltage-sensitive equipment is disconnected from the installation before the test is carried out and reconnected again immediately afterwards. The devices which may need to be disconnected before the test include:-

Storage temperature and humidity
LED indication of live circuit warning

-10 to +50°C, relative humidity 75% or less, no condensation.

Illuminates if there is an alternating voltage of 50V AC or more in the circuit under test before continuity or insulation resistance tests. When DC voltage is detected across the measuring terminal the LED lights up.

LED indication of correct Polarity
The P-E and P-N LEDs illuminate when the wiring of the circuit under test is correct. The  reverse lamp is lit when P and N are reversed.

Auto data hold
In the loop impedance, PSC and RCD test functions, the LCD reading is automatically frozen for 3 seconds after measurement.

Display
The liquid crystal display has 3 1/2 digits with a decimal point and units of measurement (Ω , M Ω , A, kA, V and ms) relative to selected function. The display is updated approximately five times per second.

Overload protection
The continuity test circuit is protected by a 0.5 A 600 V fast acting (HRC) ceramic fuse mounted in the battery compartment, where a spare fuse is also stored.

The insulation resistance test circuit is protected by a resistor against 1000 V AC for 10 seconds.

Mains Voltage Indication
On connecting test leads to the circuit under test on Loop, PSC and RCD ranges, the LCD reads V-PE. Sign "V-PE Lo" or "V-PE Hi" is also shown when the voltage is 100V or less, or 260V or greater respectively.

7. PROSPECTIVE SHORT CIRCUIT CURRENT (PSC) TESTS

 **WARNING**
NEVER CONNECT THIS INSTRUMENT ACROSS 2 PHASES.
NEVER ATTEMPT TO MEASURE THE PHASE TO PHASE PROSPECTIVE SHORT CIRCUIT CURRENT.

7.1 What is Prospective Short Circuit Current?

The Prospective Short Circuit or Fault Current at any point within an electrical installation is the current that would flow in the circuit if no circuit protection operated and a complete (very low impedance) short circuit occurred. The value of this fault current is determined by the supply voltage and the impedance of the path taken by the fault current. Measurement of Prospective Short Circuit Current (PSC) can be used to check that protective devices within the system will operate within safety limits and in accordance with the safe design of the installation.

7.2 Testing Prospective Short Circuit Current

PSC is normally measured at the distribution board between the phase and neutral, or at a socket outlet between phase and earth.

If testing at a distribution board proceed as follows:-

1. Select the 200A, 2000A or 20kA range.
2. Connect the SL 16E distribution board lead to the IEC socket on the instrument.
3. Connect the red phase probe of the SL 16E to the phase of the system, the black probe to the neutral of the system and the green crocodile clip to the neutral of the system.
4. Carry out the initial checks.
5. Press the test button. A beep will sound as the test is conducted and the value of PSC will be displayed.
6. Wait for the display to clear to zero before conducting another test or disconnecting the instrument. It is good practice to disconnect the phase lead first.

Note : For loop impedances greater than 50 Ω (PSC less than 5A approx) it is not possible to obtain an accurate PSC reading and the unit will lock out the PSC range by displaying the "OL" over-range symbol.

If the PSC ranges are selected whilst connected to a socket outlet via the mains lead KAMP10, a test will take place between Phase and Earth due to fixed wiring of the moulded mains plug i.e. a **Phase-Earth fault current** test.

CONTENTS

M E M O

1. Safe Testing.....	1
2. Features.....	3
3. Specification.....	6
4. Continuity (resistance) tests.....	9
4.1 Instrument layout.....	9
4.2 Test procedure.....	9
5. Insulation Tests.....	11
5.1 The nature of insulation resistance.....	11
5.1.1 Capacitive current.....	11
5.1.2 Conduction current.....	12
5.1.3 Surface leakage current.....	12
5.1.4 Total leakage current.....	13
5.1.5 Damage to voltage sensitive equipment.....	13
5.2 Preparation for measurement.....	14
5.3 Insulation resistance measurement.....	14
5.4 Loop Impedance Tests.....	17
6.1 Voltage measurement.....	17
6.2 What is earth fault loop impedance?.....	17
6.3 Automatic over temperature cut out.....	17
6.4 The loop impedance test.....	18
6.5 Loop impedance at 3 phase equipment.....	19
7. Prospective Short Circuit Current (PSC) tests.....	21
7.1 What is Prospective Short Circuit?.....	21
7.2 Testing Prospective Short Circuit Current.....	21
8. RCD Tests.....	22
8.1 Purpose of RCD Test.....	22
8.2 What does the RCD test really do.....	22
8.3 RCD testing.....	22
8.4 Testing RCD's used to provide supplementary protection.....	23
8.5 Testing time delayed RCD's.....	23
8.6 Testing DC sensitive RCD's.....	24
9. General.....	24
10. Battery replacement.....	25
11. Fuse replacement.....	25
12. Servicing.....	26
13. Case and Strap assembly.....	27

if earthed metal is touched during the test.

MAKE SURE TO KEEP CLEAR OF EARTHED METAL DURING THE OPERATION OF THIS TEST.

Note : If the RCD does not trip the tester will supply the test current for a maximum of 2000ms on the X1/2 and X1 ranges. The fact that the RCD has not tripped will be evident because the PN and PE LEDs will still be ON.

8.6 Testing DC sensitive RCDs

The KTS 1620 has a facility to test RCDs that are sensitive to DC fault currents. It is primarily designed to test breakers of 30mA trip rating.

Proceed as follows:

1. Set the RCD rated tripping current to 30mA.
2. Set the function switch to DC test position.
3. Press the phase selector switch to indicate 0° on the display.
4. Make sure that the P-E and P-N wiring check lamps are lit. If they are not, disconnect the tester and check the wiring for a possible fault.
5. If the lamps are lit, press the test button to apply rated tripping current and the RCD should trip, the tripping time being shown on the display.
6. Press the phase selector switch to indicate 180° in the display and repeat the test.

MAKE SURE TO KEEP CLEAR OF EARTHED METAL DURING THE OPERATION OF THIS TEST

9. GENERAL

The test button can be locked down for ease of use by pressing it and turning clockwise. Do not forget to release test button by turning it anti-clockwise before disconnecting the instrument from the test points. Failure to do so may leave the tested circuit in a charged condition when carrying out insulation test.

The instrument is provided with a sliding cover to ensure that leads for testing continuity and insulation resistance cannot be connected at the same time as test leads for loop testing and RCD testing. If this sliding cover is damaged so that it fails to perform its function, do not use the instrument and return it to Robin Electronics for attention.

Wiring check

Over temperature protection

Phase angle selector

DC Test

Auto data hold

Auto power off

V-NE Monitoring Circuit

Three LEDs indicate if the wiring of the circuit under test is correct.

Detects overheating of the internal resistor (used for loop and PSC tests) and of the current control MOS FET (used for RCD tests) displaying a warning symbol (⚡) and automatically halting further measurements.

The test can be selected from either the positive (0°) or from the negative (180°) half-cycle of voltage. This will prevent tripping of some polarised RCDs when loop testing and may give a more accurate reading when testing RCDs.

Allows testing of RCD's which are sensitive to DC fault currents.

Holds the displayed reading for a time after the test is complete.

Automatically switches the instrument off after a period of approximately 10 minutes. The power-off state returns to normal when the rotary switch is re-set to any power-on position.

Automatically aborts measurement when the N-E voltage rises to 50V or greater on RCD ranges.



The KTS 1620 Multi-Function tester performs six functions in one instrument.

1. Continuity tester
2. Insulation resistance tester
3. Loop impedance tester
4. Prospective short circuit current tester
5. RCD tester
6. Mains voltage warning when operating the loop impedance and RCD mode.

The tester is designed to Safety Standard IEC 1010-1/BS EN 61010-1 CAT III (300V).

The instrument is supplied with:-

1. An SL 16E distribution board or lighting circuit test lead for loop/PSC/RCD testing.
2. A KAMP10 lead for loop/RCD testing at socket outlets.
3. An SL20 lead for insulation and continuity testing.
4. External Earth Probe for loop testing.

In the insulation resistance testing mode the instrument provides a rated current of 1mA as required in BS 7671 (IEE Wiring Regulations) and BS EN 61557-2:1997.

In the continuity testing mode the instrument provides a short circuit current of 200mA as required in BS 7671 (IEE Wiring Regulations) and BS EN 61557-4:1997.

Continuity and insulation resistance functions have the following features:-

- Live circuit warning A colour coded LED warns if the circuit under test is live.
- Continuity Null Allows automatic subtraction of test lead resistance from continuity measurements.
- Polarity switch Allows switching of polarity during continuity tests.
- Auto discharge Electric charges stored in capacitive circuits are discharged automatically after testing by releasing the test button.

Loop impedance, PSC and RCD testing functions have the following features:-
Voltage level

In the loop impedance mode, supply voltage is displayed when the instrument is connected to the supply until the test button is pressed.

10. BATTERY REPLACEMENT

When the display shows the low battery indication, (), disconnect the test leads from the instrument. Remove the battery cover and the batteries. Replace with eight (8) new 1.5 V R6 or LR6 batteries, taking care to observe correct polarity. Replace the battery cover.

11. FUSE REPLACEMENT

The continuity test circuit is protected by a 600 V 0.5 A HRC ceramic type fuse situated in the battery compartment, together with a spare. If the instrument fails to operate in the continuity test mode, first disconnect the test leads from the instrument. Next remove the battery cover, take out the fuse and test its continuity with another continuity tester. If it has failed, replace it with a spare, before refitting the battery cover. Do not forget to obtain a new fuse and place it in the spare position.

If the instrument will not operate in the loop impedance, PSC and RCD modes, it may be that the protective fuses fitted on the printed circuit board have blown. If you suspect that the fuses have failed, return the instrument to Robin Electronics for service - do not attempt to replace the fuses yourself.

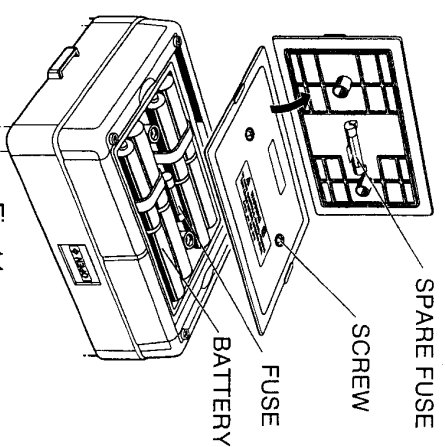

Fig 11

Quality and reliability is our tradition

Distributor

Robin Electronics Limited
Precision Centre
Dwight Road
Watford
Herts
WD1 8HG

Telephone Sales: 01923 218744
Administration: 01923 232000
Fax 01923 218898

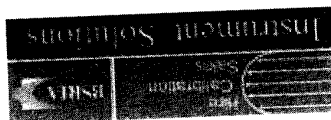

BSRIA Instrument Solutions
Old Bracknell Lane West, Bracknell, Berkshire, RG12 7AH, UK
Tel: +44 (0) 1344 459314 Fax: +44 (0) 1344 465556
Sales : sales@bis.fm Hire : hire@bis.fm Calibration : calibration@bis.fm

Home | News | Products A to Z | My Quote | Contact Us | About Us
Sales Hire
Thermal Imaging Site Services

Electrical / Multifunction - installation testers

New search

Robin : KTS 1620



The KTS1620 is Robin's mid level 5 in 1 Digital multifunction tester for electrical installations to the requirements of BS 7671.

The KTS1620 provides 5 primary test functions of

- Continuity Tester
- Insulation Tester
- Loop Impedance tester
- RCD Tester.
- PSC Tester.

All in a compact, light, and portable design. Included with the KTS 1620 as standard are SL20 Snap-Lok Test Leads; distribution board test leads, BS 1363 moulded plug lead, carrying case; Instruction Manual, & Certificate of Conformity.

KEY FEATURES

- Continuity & Insulation Test Function
- Visual Live Circuit warning lamp.
- Continuity Null function. Enables the removal of test lead resistance
- Auto discharge. Allows fast & safe electrical discharge of capacitance testing.
- Integral Overload protection. Protection on internal continuity & insulation test function voltages.
- Polarity switch. Allows switching of polarity during Insulation & continuity testing.

KEY FEATURES (Cont'd)

- LOOP Impedance Test Functions
- Visual correct wiring warning lamp.
- Integral Overheat protection. Protection on internal circuitry against
- Supply voltage indication.
- Low current Loop Impedance Test.
- Auto Data hold.
- Auto Power Off.
- RCD Test Functions
- Auto Data hold.
- Phase angle selection. Selection of test current from +ve & -ve half
- x1/2, x1 & x5 RCD current multiplier's.
- DC Test. Allows the testing of RCD's which are sensitive to DC fault
- 19 Possible test RCD trip current settings.

FUNCTION RANGE ACCURACY

- Continuity Resistance 0 to 19.99 ohm
- 10.0 to 199.9 ohm
- 100 to 2000 ohm $\pm(1.5\%$ ind + 3 digits)
- $\pm(1.5\%$ ind + 3 digits)
- Insulation Resistance
- (250, 500, 1000V DC) 0 to 100 Mohm
- 100 to 2000 Mohm $\pm(1.5\%$ ind + 3 digits)
- $\pm(1.5\%$ ind + 3 digits)
- Loop Impedance 20.00 ohm (Nominal 25 A current)
- 200.0 ohm (Nominal 2.3 A current)
- 2000 ohm (Nominal 225 mA Current) $\pm(2\%$ ind + 2 digits)
- RCD Testing x1/2 :- 5, 15, 50, 150, 250, 500 mA
- x1 :- 10, 30, 100, 300, 500, 1000 mA
- x5 :- 50, 150, 500 mA $\pm(1\%$ ind + 3 digits) trip time

KTS 1620

Home : Sales : Hire : Services : Calibration : Contact Us
Privacy policy : Copyright © 2002 BSRIA Instrument Solutions : Terms and Conditions : Logout :

[Top of page](#)

Do you know a colleague who will be interested in these products? [Send them a link to this page.](#)

[Email this page](#)



Get quote to... Buy quantity... 1 add to quote

[Quote](#)

KTS 1620 Models, availability and pricing

Price	Availability	
Call	<input type="checkbox"/>	Hire
Call	<input type="checkbox"/>	Sale
Call	<input type="checkbox"/>	Calibration

INDUSTRIAL CALIBRATION LIMITED

REPAIR AND CALIBRATION OF TEST EQUIPMENT

INSURANCE SOLUTIONS

Sales : sales@bis.fim Hire : hire@bis.fim Calibration : calibration@bis.fim

Site Services

Thermal Imaging

Calibration

Hire

Sales

Home | News | Products A to Z | My Quote | Contact Us | About Us

Electrical / Multifunction - installation testers

New search

Robin : KTS 1620

The KTS1620 is Robin's mid level 5 in 1 Digital multifunction tester for electrical installations to the requirements of BS 7671.

The KTS1620 provides 5 primary test functions of

- Continuity Tester
- Insulation Tester
- Loop Impedance tester
- RCD Tester.
- PSC Tester.

All in a compact, light, and portable design. Included with the KTS 1620 as standard are SL20 Snap-Lock Test Leads; distribution board test leads, BS 1363 moulded plug lead, carrying case.

KEY FEATURES

- Continuity & Insulation Test Function
- Visual Live Circuit warning lamp.
- Continuity Null function. Enables the removal of test lead resistance
- Auto discharge. Allows fast & safe electrical discharge of capacitance testing.
- Integral Overload protection. Protection on internal continuity & insulation testing.
- Integral Overload protection. Protection on internal continuity & insulation testing.
- 250, 500V & 1000V DC Insulation test function voltages.
- Polarity switch. Allows switching of polarity during Insulation & continuity testing.

KEY FEATURES (Cont'd)

- LOOP Impedance Test Functions
- Visual correct wiring warning lamp.
- Integral Overheat protection. Protection on internal circuitry against
- Supply voltage indication.
- Low current Loop Impedance Test.
- Auto Data hold.
- Auto Power Off.
- RCD Test Functions
- Auto Data hold.
- Phase angle selection. Selection of test current from +ve & -ve half
- x1/2, x1 & x5 RCD current multipliers.
- DC Test. Allows the testing of RCD's which are sensitive to DC fault
- 19 Possible test RCD trip current settings.

FUNCTION RANGE ACCURACY

- Continuity Resistance 0 to 19.99 ohm
- 10.0 to 199.9 ohm
- 100 to 2000 ohm $\pm(1.5\% \text{ ind} + 3 \text{ digits})$
- $\pm(1.5\% \text{ ind} + 3 \text{ digits})$
- $\pm(1.5\% \text{ ind} + 3 \text{ digits})$
- Insulation Resistance
- (250, 500, 1000V DC) 0 to 100 Mohm
- 100 to 2000 Mohm $\pm(1.5\% \text{ ind} + 3 \text{ digits})$
- $\pm(1.5\% \text{ ind} + 3 \text{ digits})$
- Loop Impedance 20.00 ohm (Nominal 25 A current)
- 200.0 ohm (Nominal 2.3 A current)
- 2000 ohm (Nominal 225 mA Current) $\pm(2\% \text{ ind} + 2 \text{ digits})$
- RCD Testing x1/2 :- 5, 15, 50, 150, 250, 500 mA
- x1 :- 10, 30, 100, 300, 500, 1000 mA
- x5 :- 50, 150, 500 mA $\pm(1\% \text{ ind} + 3 \text{ digits})$ trip time

Date

Signature

Home : Sales : Hire : Services : Calibration : Contact Us
Privacy policy : Copyright © 2002 BSRIA Instrument Solutions : Terms and Conditions : Logout :

[Top of page](#)

Do you know a colleague who will be interested in these products? [Send them a link to this page.](#)

[Email this page](#)



Get quote to... Buy quantity...1 add to quote

[Quote](#)

Availability	Price	Hire	Sale	Calibration
<input type="checkbox"/>	Call	<input type="checkbox"/>	Call	<input type="checkbox"/>
<input type="checkbox"/>	Call	<input type="checkbox"/>	Call	<input type="checkbox"/>
<input type="checkbox"/>	Call	<input type="checkbox"/>	Call	<input type="checkbox"/>

KTS 1620

[Models, availability and pricing](#)

INDUSTRIAL CALIBRATION LIMITED

REPAIR AND CALIBRATION OF TEST EQUIPMENT



Robin KTS 1620